

# iM222A-ZNP (ZigBee Network Processor)

Datasheet Version 2.2



Document ID: 4100/6404/0042

---

IMST GmbH  
Carl-Friedrich-Gauss-Str. 2  
D-47475 Kamp-Lintfort



## Document Information

|                    |                          |
|--------------------|--------------------------|
| <b>File name</b>   | iM222A-ZNP_Datasheet.doc |
| <b>Created</b>     | 2011-03-08               |
| <b>Total pages</b> | 25                       |

## Revision History

| <b>Version</b> | <b>Change</b>   |
|----------------|---|
| 1.0            | Released version.   |
| 2.0            | Modifications to document format and layout. Added chapter 4.3, 8, and 9. |
| 2.1            | Updated Table 3-1   |
| 2.2            | FCC and IC statement added.   |
|                |   |

## Aim of this Document

The aim of this document is to give a detailed product description including interfaces, features and performance of the radio module iM222A-ZNP.

## Table of Contents

|     |                                       |    |
|-----|---------------------------------------|----|
| 1   | SUMMARY / INTRODUCTION                | 5  |
| 1.1 | Key Features                          | 5  |
| 1.2 | Applications                          | 5  |
| 2   | MODULE OVERVIEW                       | 6  |
| 3   | SPECIFICATION                         | 7  |
| 3.1 | Absolute Maximum Ratings              | 7  |
| 3.2 | General Characteristics               | 7  |
| 3.3 | Module Interface Characteristics      | 8  |
| 3.4 | RF Characteristics                    | 9  |
| 3.5 | Pinout Description                    | 10 |
| 3.6 | Module Dimension                      | 12 |
| 3.7 | Recommended Footprint                 | 12 |
| 4   | INTEGRATION GUIDE                     | 13 |
| 4.1 | Typical Application Schematic         | 13 |
| 4.2 | PCB Design Recommendation             | 15 |
| 4.3 | Recommended Soldering Conditions      | 16 |
| 5   | ZIGBEE FEATURES                       | 17 |
| 5.1 | iM222A-ZNP Software Command Interface | 17 |
| 5.2 | Additional Documents                  | 18 |
| 6   | PACKAGING INFORMATION                 | 19 |
| 6.1 | Carrier Tape Information              | 19 |
| 6.2 | Reel Information                      | 19 |
| 7   | ORDERING INFORMATION                  | 20 |
| 8   | APPENDIX                              | 21 |
| 8.1 | List of Abbreviations                 | 21 |
| 8.2 | List of Figures                       | 22 |
| 8.3 | List of Tables                        | 22 |

|      |                                   |    |
|------|-----------------------------------|----|
| 8.4  | References                        | 23 |
| 9    | REGULATORY COMPLIANCE INFORMATION | 23 |
| 10   | IMPORTANT NOTICE                  | 25 |
| 10.1 | Disclaimer                        | 25 |
| 10.2 | Contact Information               | 25 |

# 1 Summary / Introduction

The iM222A-ZNP is a compact, low power, bidirectional radio module for the 2.4 GHz frequency band. Using the iM222A-ZNP in an application minimizes the need for an expensive and time-consuming RF development. Fast time to market is possible with this module. With the integrated ZigBee Network Processor firmware<sup>1</sup> the iM222A-ZNP offers the opportunity to add full ZigBee PRO network support to an existing application via an easy to use serial interface. With less than 10 commands a complete ZigBee PRO network can be built and maintained without deep knowledge of the ZigBee stack.

Additionally the module has enough processing power to run an entire ZigBee application on top of the ZigBee Stack from Texas Instruments. IMST offers development support for any type of application on the basis of the iM222A, including different IEEE 802.15.4-based standards like 6LoWPAN, RF4CE and others.



This datasheet includes the hardware specifications and describes the features of the iM222A-ZNP as well as the possible RF settings. A brief instruction of the ZigBee features that come along with the ZigBee Network Processor firmware is given.

## 1.1 Key Features

- Complete ZigBee Ready module
- Output power up to 4.5 dBm
- Excellent Link budget of 101 dBm
- Integrated antenna or 50 Ohm pad
- UART, SPI and Debug interface
- 256 kB Flash memory, 8 kB RAM
- 12-Bit ADC
- 128-Bit AES encryption engine
- ZigBee Network Processor firmware
- Mesh-, Clustertree-, Star-Networks
- AODV-, Many-To-One and Source-Routing
- Easy-to-use API over UART/SPI
- Bootloading support

## 1.2 Applications

- 2.4 GHz IEEE802.15.4 systems
- ZigBee PRO systems
- Low-Power wireless sensor networks
- RF remote control and RF4CE systems
- Smart Metering systems
- Home-, Building-, Industrial Automation
- Lighting systems
- Health Care
- Consumer Electronics
- ...

Please visit our web site [www.wireless-solutions.de](http://www.wireless-solutions.de) for more information.

---

<sup>1</sup> Part of the Z-Stack available from Texas Instruments

## 2 Module Overview

The iM222A-ZNP is a small radio module for the 2.4 GHz frequency band. It provides a complete RF/MCU design including a transceiver, a microcontroller with AES coprocessor, a PCB antenna, and all necessary passive components as depicted in Figure 2-1. The iM222A-ZNP integrates a complete full feature ZigBee PRO stack with an easy to use API that is accessible either via UART (default) or via SPI.

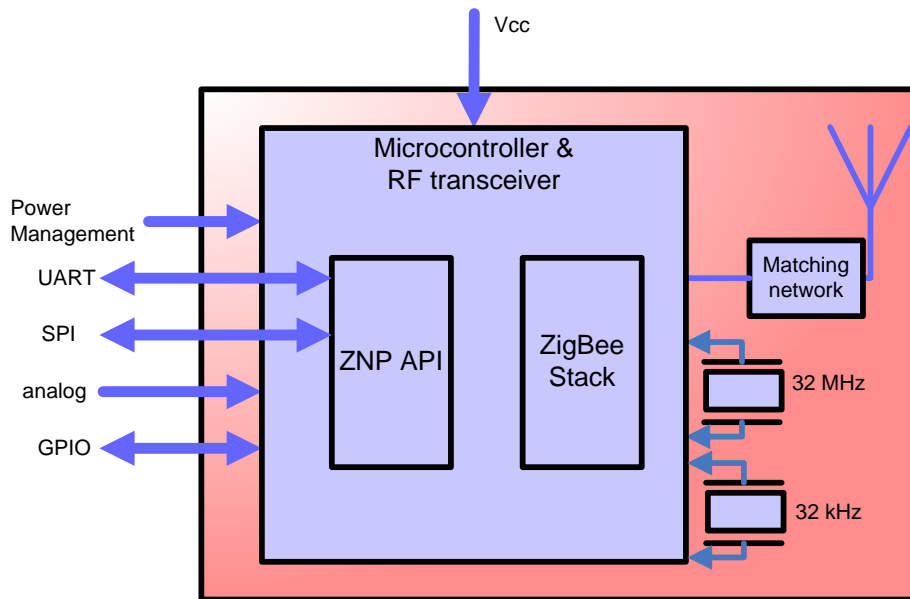

Figure 2-1: Block Diagram - iM222A-ZNP

The module runs the ZigBee Network Processor firmware from Texas Instruments. In addition to full ZigBee Device Object and ZigBee Application Framework API support, this firmware features a simple API that makes it possible to establish a ZigBee network with less than 10 commands. The firmware API can be easily tested by using TI's Z-TOOL pc software via TTL/USB bridge (included on WiMOD Demo Board). Low power consumption is achieved with an integrated low frequency crystal unit that enables sleep mode support for ZigBee end devices (this feature is only available when using SPI configuration).

Integrated bootloading functionality enables the user to make a firmware update over the UART interface. To use the bootloader an upload tool which is part of the Z-Stack package from TI (SBDemo) has to be used.

The module is solderable like a SMD-component and can easily be mounted on a simple carrier board with a minimum of required external connections. It is RoHS compliant and pre-qualified in accordance to ETSI EN 300 440-2 V1.4.1.

## 3 Specification

### 3.1 Absolute Maximum Ratings

| Parameter             | Range            | Unit | Condition                           |
|-----------------------|------------------|------|-------------------------------------|
| Supply voltage        | -0.3 to 3.9      | V    |                                     |
| Input voltage         | -0.3 to VCC +0.3 | V    | Any Digital pin                     |
| DC current            | 4                | mA   | Per digital pin                     |
|                       | 20               | mA   | Only radio module pin 14 and pin 15 |
| Operating temperature | -20 to +70       | °C   |                                     |
| Storage temperature   | -40 to +85       | °C   |                                     |

Table 3-1: Absolute Maximum Ratings

**Note:** Stress exceeding of one or more of the limiting values listed under “Absolute Maximum Ratings” may cause permanent damage to the radio module.

### 3.2 General Characteristics

T = 25°C, VDD = 3V (typ.) if nothing else stated

| Parameter                      | Range         | Unit | Condition                                   |
|--------------------------------|---------------|------|---|
| Operating supply voltage VCC   | 2.0 to 3.6    | V    | Typ. 3.0 V                                  |
| Current consumption            | typ. 24.3     | mA   | Receive mode                                |
|                                | typ. 28.5     | mA   | Transmit @ 0 dBm                            |
|                                | typ. 33.5     | mA   | Transmit @ max. RF output power             |
|                                | typ. 3.4      | mA   | μC active, TRX off                          |
|                                | typ. 1        | μA   | Power mode 2, 32.768kHz crystal             |
|                                | typ. 0.4      | μA   | Power mode 3                                |
| Dimension (L x W x H)          | 20 x 25 x 2.7 | mm   | ±0.2mm                                      |
| MCU operation frequency        | 32            | MHz  |   |
| Real time oscillator frequency | 32.768        | kHz  |   |
| Memory (Flash)                 | 256           | KB   | Minimum endurance: 1000 write/erase cycles. |
| Memory (RAM)                   | 8             | KB   |   |

Table 3-2: General Characteristics

### 3.3 Module Interface Characteristics

T = 25°C, VDD = 3V (typ.) if nothing else stated

| Parameter   | Range      | Unit | Condition  |
|---|------------|------|--|
| Digital output voltage  | 2.4 to VCC | V    | High level   |
|   | GND to 0.5 | V    | Low level  |
| Digital input voltage   | 2.5 to VCC | V    | High level   |
|   | GND to 0.5 | V    | Low level  |
| I/O pin pull-up/pull-down resistor  | 20         | kΩ   |  |
| Pulse width on /RESET pin   | min. 2.5   | μs   | Low active pin. See Note 1.                              |
| UART baud rate  | typ. 115.2 | kbps |  |
| SPI baud rate   | max. 4000  | kbps |  |
| ADC resolution  | 7 to 14    | Bit  |  |
| ADC conversion time   | 20 to 132  | μs   | Depends on ADC resolution<br>(68 μs @ 10 bit resolution) |
| ADC input resistance  | 197        | kΩ   |  |
| Analog int. reference voltage   | 1.15       | V    |  |
| Notes:  |            |      |  |
| 1) Shorter pulses may be recognized but will not lead to complete reset of all units within the module. |            |      |  |

Table 3-3: Module Interface Characteristics

**Note:** Additional to the reset pin the module has a Power-On-Reset (POR) functionality which holds the module in reset state until supply voltage increase above the POR threshold (rising edge). It will not work unless VCC has been below POR threshold (falling edge). See chapter 3.5 for additional information to the POR feature.

All radio module IOs except DIO\_7 and DIO\_8 are configured as input with pull-up resistor when a reset condition becomes active.



### 3.4 RF Characteristics

T = 25°C, VDD = 3V (typ.) if nothing else stated

| Parameter  | Range        | Unit | Condition   |
|--|--------------|------|---|
| Frequency range                                      | 2405 to 2480 | MHz  | 16 IEEE 802.15.4 channels   |
| Channel spacing                                      | 5            | MHz  |   |
| RF data rate   | 250          | kbps |   |
| RF output power                                      | max. +4.5    | dBm  |   |
| RF output power range                                | -            | dB   | ZNP always uses maximum transmit power                            |
| RF sensitivity                                       | typ. -97     | dBm  | 1 % PER (Note 1)  |
| Modulation techniques                                | O-QPSK       |      |   |
| Range  | up to 500    | m    | Outdoor (line of sight) with external antenna (0 dBi) on pin ANT. |
| Notes:   |              |      |   |
| 1) PER = Packet Error Rate ; 20 bytes packet length. |              |      |   |

Table 3-4: RF Characteristics

### 3.5 Pinout Description

Figure 3-1 depicts the pinout of the iM222A-ZNP.

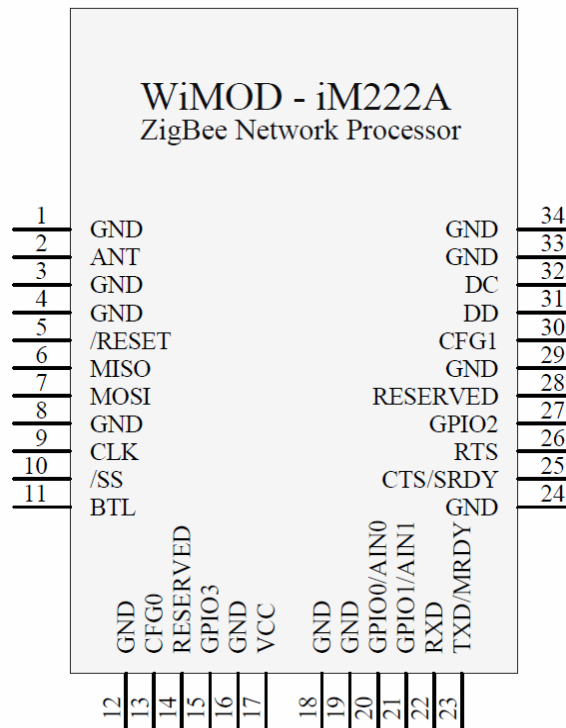

Figure 3-1: Pinout

Table 3-5 shows the mapping between iM222A-ZNP pin declarations and the CC2530 pin definitions as used in “CC2530ZNP Interface Specification.pdf” (SWRA312) from Texas Instruments. The pin functionality as well as their usage is described in the aforementioned document. Please note that the pin description in Table 3-5 reflects only the pin usage for the iM222A-ZNP (ZigBee PRO Network Processor). For a customized application with the iM222A-ZNP all peripheral features of the CC2530 can be used (see CC2530 datasheet).

**Note:** The POR functionality does not work correctly if the I/O-pins are connected to a second power supply while the radio module is powered up.

For example, if connecting the radio module to a host controller (e.g. RXD and TXD to another microcontroller) with separate power supply, it is strictly recommended to set all I/O-pins of this controller to high impedance or to GND potential when the radio module is powered down. If do not so, it is possible that the radio module is powered by the host controller over its I/O-pins with the result that the POR feature does not work correctly and the module status is undefined.

| iM222A-ZNP |            | CC2530 | Description  | PIN Type |
|------------|------------|--------|--|----------|
| PIN #      | Name       | Name   |  |          |
| 1          | GND        | GND    | Ground connection                                      | Supply   |
| 2          | ANT        |        | Ext. antenna connection. Use only after consultation.  |          |
| 3          | GND        | GND    | Ground connection                                      | Supply   |
| 4          | GND        | GND    | Ground connection                                      | Supply   |
| 5          | /RESET     | /RESET | Low active RESET input pin                             |          |
| 6          | MISO       | P1_7   | SPI MISO – Master Input Slave Output                   | OUT      |
| 7          | MOSI       | P1_6   | SPI MOSI – Master Output Slave Input                   | IN       |
| 8          | GND        | GND    | Ground connection                                      | Supply   |
| 9          | CLK        | P1_5   | SPI CLK – Serial Clock                                 | IN       |
| 10         | /SS        | P1_4   | SPI SS – Slave Select (low active)                     | IN       |
| 11         | BTL        | P1_3   | Low active bootloader pin <sup>Note 2</sup>            | IN       |
| 12         | GND        | GND    | Ground connection                                      | Supply   |
| 13         | CFG0       | P1_2   | CFG0, connect to VDD                                   | IN       |
| 14         | RESERVED   | P1_1   | Unused, do not connect                                 |          |
| 15         | GPIO3      | P1_0   | GPIO3 – configurable by software                       | IN/OUT   |
| 16         | GND        | GND    | Ground connection                                      | Supply   |
| 17         | VCC        | VCC    | Supply voltage (typ. 3V)                               | Supply   |
| 18         | GND        | GND    | Ground connection                                      | Supply   |
| 19         | GND        | GND    | Ground connection                                      | Supply   |
| 20         | GPIO0/AIN0 | P0_0   | GPIO0 / AIN0 – configurable by software                | IN/OUT   |
| 21         | GPIO1/AIN1 | P0_1   | GPIO1 / AIN1 – configurable by software                | IN/OUT   |
| 22         | RXD        | P0_2   | RXD (UART receive pin)                                 | IN       |
| 23         | TXD/MRDY   | P0_3   | TXD (UART transmit pin) / SPI MRDY                     | OUT/IN   |
| 24         | GND        | GND    | Ground connection                                      | Supply   |
| 25         | CTS/SRDY   | P0_4   | CTS (UART CTS pin) / SPI SRDY                          | IN/OUT   |
| 26         | RTS        | P0_5   | RTS (UART RTS pin)                                     | OUT      |
| 27         | GPIO2      | P0_6   | GPIO2 – configurable by software                       | IN/OUT   |
| 28         | RESERVED   | P0_7   | Unused, do not connect                                 |          |
| 29         | GND        | GND    | Ground connection                                      | Supply   |
| 30         | CFG1       | P2_0   | CFG1, GND for UART, VDD for SPI transfer mode          | IN       |
| 31         | DD         | P2_1   | Debug Data (data line for programming and debugging)   | IN/OUT   |
| 32         | DC         | P2_2   | Debug Clock (clock line for programming and debugging) | IN       |
| 33         | GND        | GND    | Ground connection                                      | Supply   |
| 34         | GND        | GND    | Ground connection                                      | Supply   |

Notes:

- 1) In “CC2530ZNP Interface Specification.pdf” PAEN, EN and HGM pins are mentioned to control an external PA/LNA. This functionality is not available on iM222A-ZNP yet. The corresponding pins (depending on interface configuration) should be left open.
- 2) Set this pin to low level during/after a reset to switch into bootloader mode for a firmware update.

Table 3-5: Pinout iM222A-ZNP

### 3.6 Module Dimension

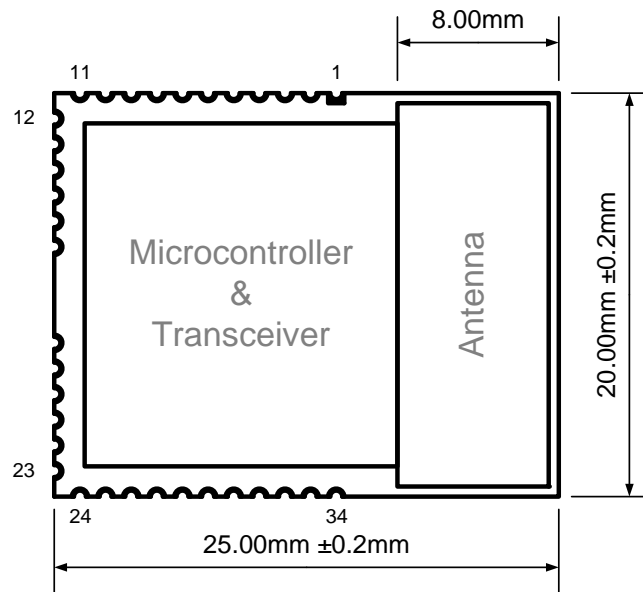

Figure 3-2: Module Dimension

### 3.7 Recommended Footprint

The pad pitch is 1.27mm.

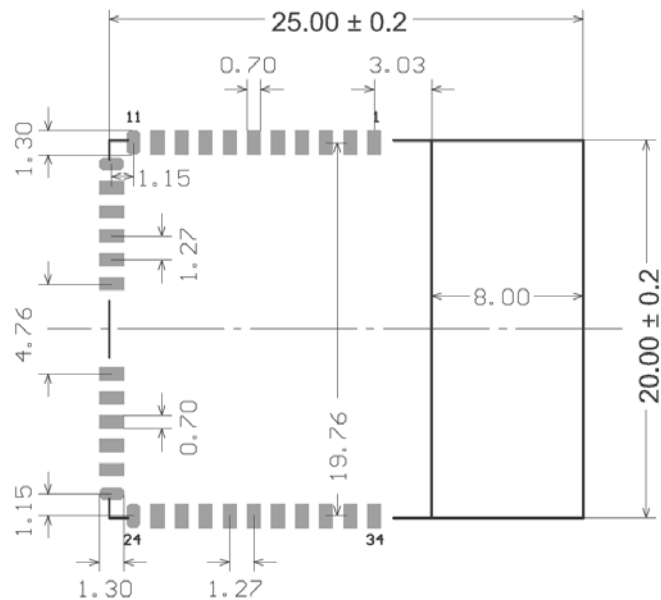

Figure 3-3: Footprint

All dimensions are in millimeters.

## 4 Integration Guide

### 4.1 Typical Application Schematic

Figure 4-1 shows a schematic of a typical application when using the iM222A-ZNP in UART (default) mode.

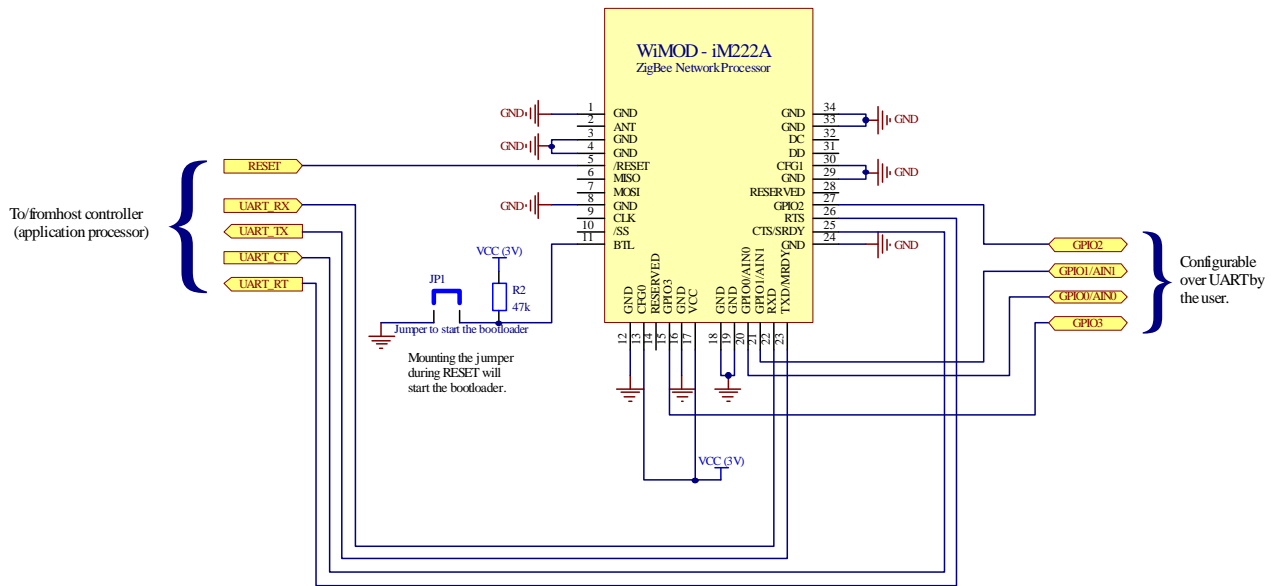

Figure 4-1: Sample application schematic using UART communication

Pin CFG1 must be set to logical zero to configure the iM222A-ZNP for UART mode operation and pin CFG0 must be set to logical one to indicate the presence of the iM222A-ZNP sleep crystal (32.768 kHz). Please note, that power-saving features are not available when using UART transport mode, for low-power operations the SPI transport mode is recommended.

The UART pins (TXD, RXD, CTS, RTS) can be connected to a host controller (application processor) or to a host PC (via level converter) for serial communication. In the latter case the Z-Tool can be used to configure the device. Optionally the RESET pin can be connected to the application processor to reset the iM222A-ZNP by this processor.

The pins GPIO0-3 are application specific and can be configured over the serial interface. It must be ensured that the maximum DC current per pin (see Table 3-1) is not exceeded.

**Note:** Pin BTL has to be set to low level during/after a reset to switch into bootloader mode for a firmware update over the serial interface.

Figure 4-2 shows a schematic of a typical application when using the iM222A-ZNP in SPI mode (iM222A-ZNP = SPI slave).

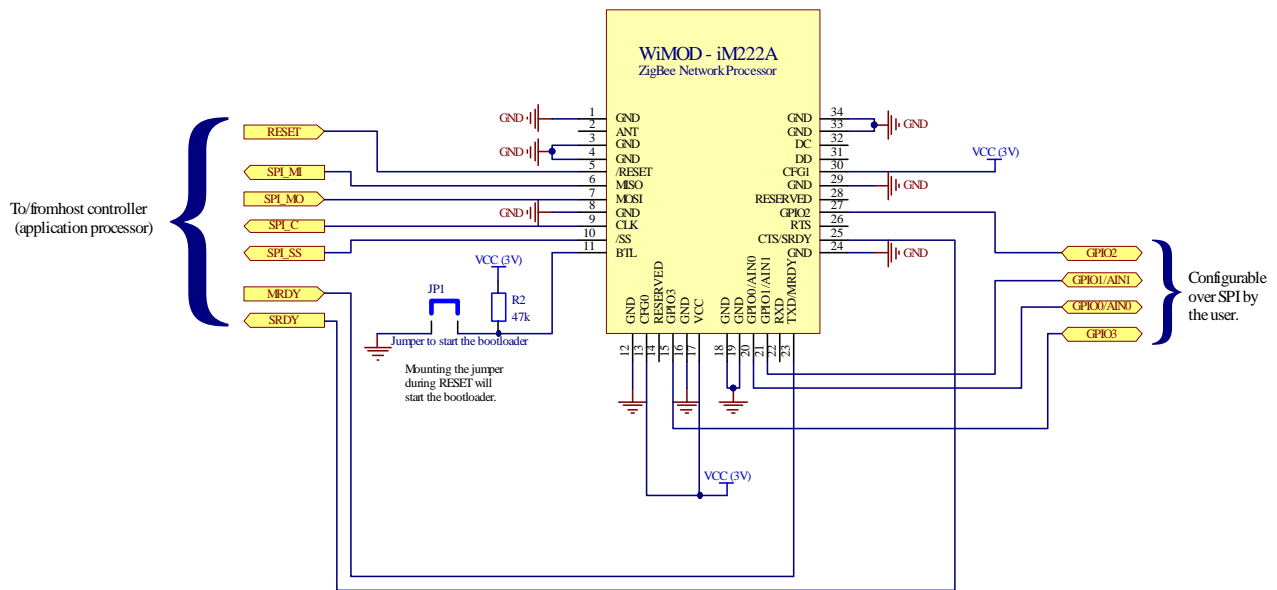

Figure 4-2: Sample application schematic using SPI communication

Pin CFG1 must be set to logical one to configure the iM222A-ZNP for SPI mode operation and pin CFG0 must be set to logical one to indicate the presence of the iM222A-ZNP sleep crystal (32.768 kHz).

The SPI pins (MISO, MOSI, CLK, /SS) have to be connected to host controller application processor for serial communication. Additionally pins MRDY and SRDY have to be connected to the application processor for SPI transaction control and power management. Optionally the RESET pin can be connected to the application processor to reset the iM222A-ZNP by this processor.

The pins GPIO0-3 are application specific and can be configured over the serial interface. It must be ensured that the maximum DC current per pin (see Table 3-1) is not exceeded.

**Note:** Pin BTL has to be set to low level during/after a reset to switch into bootloader mode for a firmware update over the serial interface.

## 4.2 PCB Design Recommendation

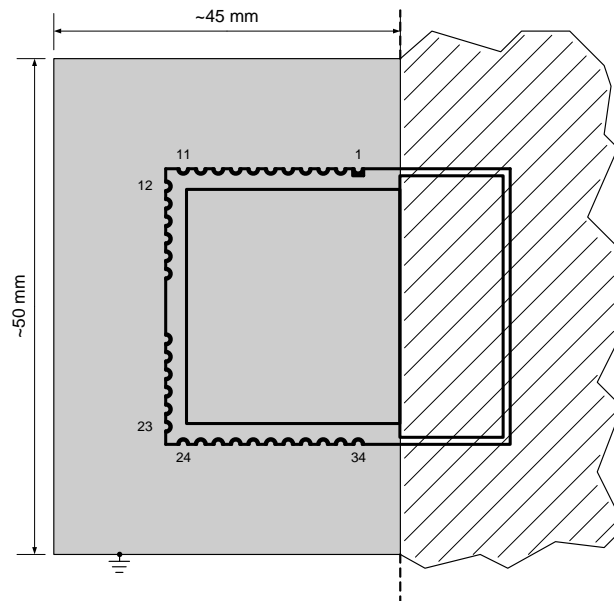

Figure 4-3: Recommended Environment

When designing a carrier board layout for the iM222A-ZNP the following design considerations are recommended:

- The Top Layer of the carrier board should be kept free of tracks and vias under the iM222A-ZNP because there are some testpads on the bottom side of the module which are not covered by solder resist.
- As shown in Figure 4-3, the solid grey area must be a ground-plane on the Bottom Layer (or Layer 2 in a multi-layer structure) of the carrier board. Antenna matching and all other measurements have been done with these dimensions.

**Info:** Other dimensions can affect the RF performance respective RF output power, sensitivity, and unwanted emissions. Maybe the matching network of the integrated PCB antenna must be renewed.

- All radio module ground pads must be directly connected to the ground-plane by vias next to each ground pad.
- The hatched area shown in Figure 4-3 has to be free of material (e.g. PCB, metal, housing). If possible, the distance from the antenna area to any material should be at least  $\lambda/2$  <sup>see 1</sup>.

<sup>1</sup> At 2.4 GHz it is approximately 62.5 mm.

### 4.3 Recommended Soldering Conditions

An example of the temperature profile for the reflow soldering process of the iM222A-ZNP is depicted in Figure 4-4 with the corresponding values as given by Table 4-1. The temperature values should not exceed the limits.

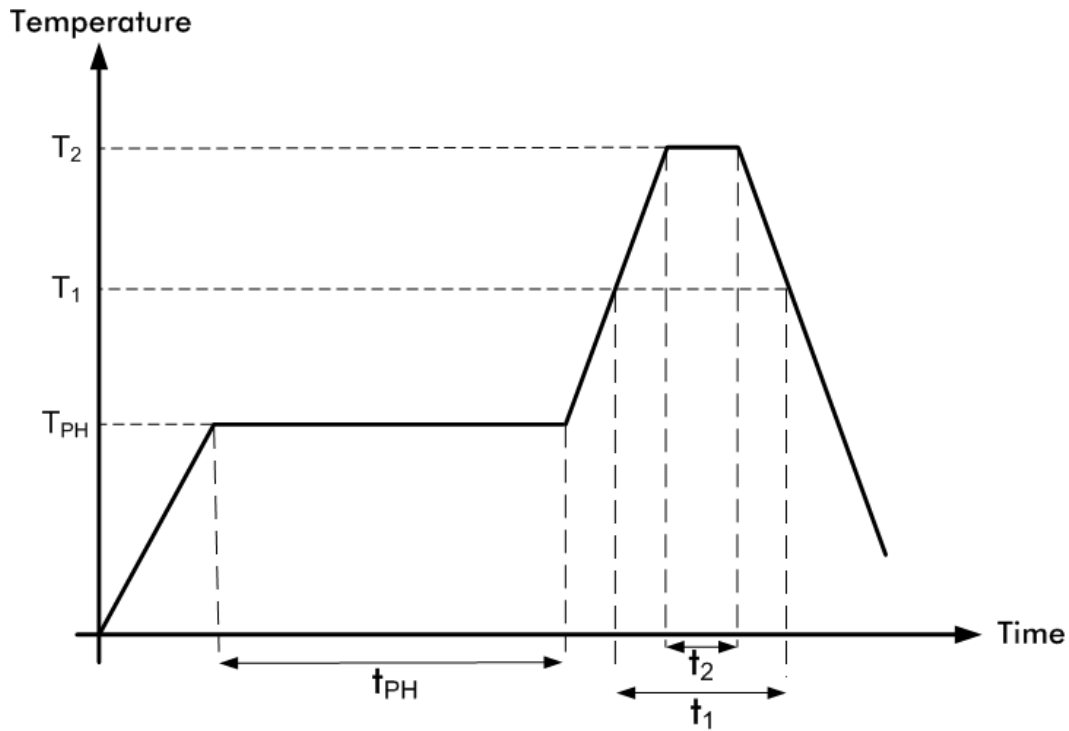

Figure 4-4: Recommended Solder Reflow Profile

| Phase        | Pb-Free Conditions                                 |
|--------------|--|
| Preheating   | $t_{PH} = 120s$<br>$T_{PH} = 160\sim 180^{\circ}C$ |
| Primary heat | $t_1 = 60s$<br>$T_1 = 220^{\circ}C$                |
| Peak         | $t_2 = 10s$ (max)<br>$T_2 = 255^{\circ}C$          |

Table 4-1: Recommended Soldering Parameter for Temperature and Timing

**Note:** The quality of the soldering process depends on several parameters, e.g. soldering paste, carrier board design, fabrication equipment,...



## 5 ZigBee Features

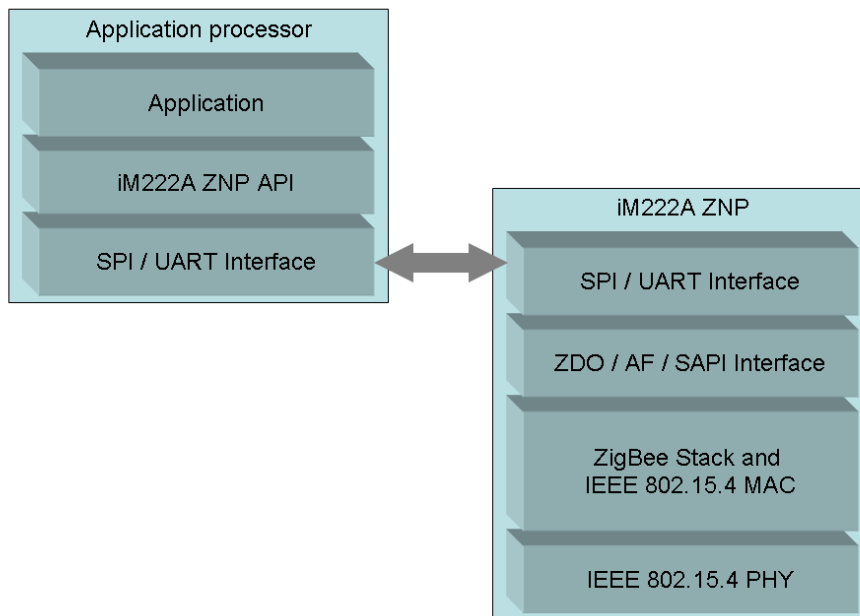

Figure 5-1: iM222A ZNP Stack overview

The iM222A-ZNP integrates a full ZigBee protocol stack including PHY, MAC and NWK but does not include high level ZigBee applications. The ZigBee application has to be implemented on the host processor and registers itself only to the ZigBee processor of the iM222A-ZNP to obtain access to the ZigBee functionality. The application does not necessarily need to be a ZigBee certified product. It is also possible to use the Simple Application Interface to benefit of the ZigBee routing and networking features without taking care on ZigBee conformance.

It is recommended to check the stack/protocol version and the actual documentation version number. This can be achieved directly after the power up, the SYS\_RESET\_IND should have been received, of the iM222A-ZNP by issuing the SYS\_VERSION command (see p. 20 SWRA312).

### 5.1 iM222A-ZNP Software Command Interface

The complete application interface is described in the document “CC2530ZNP Interface Specification.pdf” (SWRA312) from Texas Instruments.

1. SYS interface

Commands to get and set hardware specific parameters like local ADC readings, GPIO functions and non-volatile memory instructions.

2. Configuration interface

Read and write device specific parameters like operating frequency channel, security keys and descriptors.

### 3. Simple API interface

Easy to use API that is registered as a specific ZigBee application endpoint. This can be used for fast bindings and data exchange without long initialization and registration procedures.

### 4. AF interface

The application framework enables full ZigBee cluster and endpoint registration as well as source routing data requests and inter pan communication.

### 5. ZDO interface

The ZigBee device object interface offers network discovery and maintenance functionality.

### 6. UTIL interface

This interface offers some useful commands that are not mapped within the ZDO and AF interface (e.g. a one shot Poll request on MAC layer).

## 5.2 Additional Documents

These documents give an overview of the possibilities of the iM222A-ZNP. The first document specifies the complete physical and software interface of the device. This document has to be read before beginning the hardware/software design of the iM222A-ZNP.

1. CC2530ZNP Interface Specification.pdf (SWRA312), Texas Instruments
2. Creating a ZigBee® Smart Energy Device with the MSP430F54xx and the CC2530-ZNP (slyy022.pdf), Texas Instruments
3. ZCL API document (SWRA197), Texas Instruments
4. Examples on how to use the ZNP interface on a host processor ([http://processors.wiki.ti.com/index.php/Tutorial\\_on\\_the\\_Examples](http://processors.wiki.ti.com/index.php/Tutorial_on_the_Examples)), Texas Instruments
5. Example software for TIs CC2530 ZDK ZNP Mini Kit (<http://focus.ti.com/docs/toolsw/folders/print/cc2530zdk-znp-mini.html>), Texas Instruments
6. CC2530 datasheet (CC2530.pdf), Texas Instruments
7. Z-Stack package (<http://focus.ti.com/docs/toolsw/folders/print/z-stack.html>), Texas Instruments

## 6 Packaging Information

### 6.1 Carrier Tape Information

All dimensions are in millimeters.

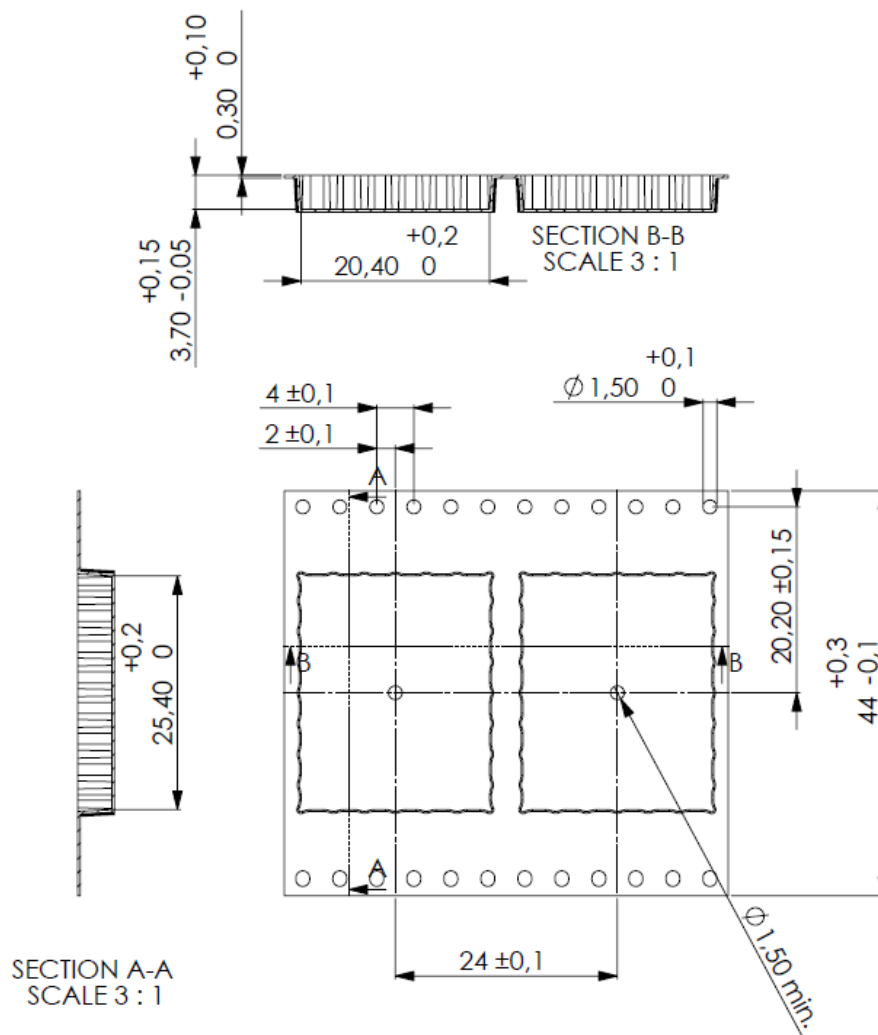

Figure 6-1: Dimensions of the iM222A-ZNP Carrier Tape

### 6.2 Reel Information

| Reel diameter | Core diameter | Core width   | Units per reel |
|---------------|---------------|--------------|----------------|
| 330mm         | 100mm         | approx. 45mm | max. 700       |

Table 2: Reel Information

## 7 Ordering Information

| Ordering Part Number | Description             | Distributor                                      |
|----------------------|-------------------------|--|
| iM222A-ZNP           | Radio module iM222A-ZNP | <a href="mailto:wimod@imst.de">wimod@imst.de</a> |
| Notes:               |                         |  |

Table 7-1: Ordering Information

## 8 Appendix

### 8.1 List of Abbreviations

|          |   |
|----------|---|
| AB       | = Adapter Board                               |
| ADC      | = Analog-to-Digital Converter                 |
| AES      | = Advanced Encryption Standard                |
| DIO      | = Digital Input/Output                        |
| E.I.R.P. | = Equivalent Isotropic Radiated Power         |
| O-QPSK   | = Offset Quadrature Phase Shift Keying        |
| GPIO     | = General Purpose Input/Output                |
| MCU      | = Microcontroller Unit                        |
| PCB      | = Printed Circuit Board                       |
| PER      | = Packet Error Rate                           |
| RAM      | = Random Access Memory                        |
| RF       | = Radio Frequency                             |
| RSSI     | = Received Signal Strength Indication         |
| SPI      | = Serial Peripheral Interface                 |
| UART     | = Universal Asynchronous Receiver/Transmitter |
| USB      | = Universal Serial Bus                        |
| ZNP      | = ZigBee Network Processor                    |
| API      | = Application Programming Interface           |
| ZNP      | = ZigBee Network Processor                    |
| ZDO      | = ZigBee Device Object                        |
| AF       | = Application Framework                       |

## 8.2 List of Figures

|   |    |
|---|----|
| Figure 2-1: Block Diagram - iM222A-ZNP .....                            | 6  |
| Figure 3-1: Pinout .....  | 10 |
| Figure 3-2: Module Dimension .....                                      | 12 |
| Figure 3-3: Footprint .....   | 12 |
| Figure 4-1: Sample application schematic using UART communication ..... | 13 |
| Figure 4-2: Sample application schematic using SPI communication .....  | 14 |
| Figure 4-3: Recommended Environment .....                               | 15 |
| Figure 4-4: Recommended Solder Reflow Profile .....                     | 16 |
| Figure 5-1: iM222A ZNP Stack overview .....                             | 17 |
| Figure 6-1: Dimensions of the iM222A-ZNP Carrier Tape .....             | 19 |

## 8.3 List of Tables

|   |    |
|---|----|
| Table 3-1: Absolute Maximum Ratings .....                                   | 7  |
| Table 3-2: General Characteristics .....                                    | 7  |
| Table 3-3: Module Interface Characteristics .....                           | 8  |
| Table 3-4: RF Characteristics .....   | 9  |
| Table 3-5: Pinout iM222A-ZNP .....  | 11 |
| Table 4-1: Recommended Soldering Parameter for Temperature and Timing ..... | 16 |
| Table 2: Reel Information .....   | 19 |
| Table 7-1: Ordering Information .....                                       | 20 |

## 8.4 References

IMST GmbH disclaims any responsibility for the contents of external links. The owner of the sites is responsible for its content. The validity of the referenced hyperlinks has been tested at publication date of this document. IMST GmbH cannot guarantee the long term validity of the hyperlinks.

## 9 Regulatory Compliance Information

### R&TTE

The use of radio frequencies is limited by national regulations. The radio module has been designed to comply with the European Union's R&TTE (Radio & Telecommunications Terminal Equipment) directive 1999/5/EC and can be used free of charge within the European Union. Nevertheless, restrictions in terms of maximum allowed RF power or duty cycle may apply.

The radio module has been designed to be embedded into other products (referred as "final products"). According to the R&TTE directive, the declaration of compliance with essential requirements of the R&TTE directive is within the responsibility of the manufacturer of the final product. A declaration of conformity for the radio module is available from IMST GmbH on request.

### FCC

This device complies with Part 15 of the FCC Rules. Operation is subject to the following two conditions: (1) this device may not cause harmful interference, and (2) this device must accept any interference received, including interference that may cause undesired operation. (FCC Part 15.19).

Warning: Changes or modifications made to this equipment not expressly approved by IMST GmbH may void the FCC authorization to operate this equipment. (FCC Part 15.21)

### IC

This device complies with Industry Canada licence-exempt RSS standard(s). Operation is subject to the following two conditions: (1) this device may not cause interference, and (2) this device must accept any interference, including interference that may cause undesired operation of the device.(RSS-GEN)

Le présent appareil est conforme aux CNR d'Industrie Canada applicables aux appareils radio exempts de licence. L'exploitation est autorisée aux deux conditions suivantes : (1)

l'appareil ne doit pas produire de brouillage, et (2) l'utilisateur de l'appareil doit accepter tout brouillage radioélectrique subi, même si le brouillage est susceptible d'en compromettre le fonctionnement. (RSS-GEN).

The applicable regulation requirements are subject to change. IMST GmbH does not take any responsibility for the correctness and accuracy of the aforementioned information. National laws and regulations, as well as their interpretation can vary with the country. In case of uncertainty, it is recommended to contact either IMST's accredited Test Center or to consult the local authorities of the relevant countries.



## 10 Important Notice

### 10.1 Disclaimer

IMST GmbH points out that all information in this document is given on an “as is” basis. No guarantee, neither explicit nor implicit is given for the correctness at the time of publication. IMST GmbH reserves all rights to make corrections, modifications, enhancements, and other changes to its products and services at any time and to discontinue any product or service without prior notice. It is recommended for customers to refer to the latest relevant information before placing orders and to verify that such information is current and complete. All products are sold and delivered subject to “General Terms and Conditions” of IMST GmbH, supplied at the time of order acknowledgment.

IMST GmbH assumes no liability for the use of its products and does not grant any licenses for its patent rights or for any other of its intellectual property rights or third-party rights. It is the customer’s duty to bear responsibility for compliance of systems or units in which products from IMST GmbH are integrated with applicable legal regulations. Customers should provide adequate design and operating safeguards to minimize the risks associated with customer products and applications. The products are not approved for use in life supporting systems or other systems whose malfunction could result in personal injury to the user. Customers using the products within such applications do so at their own risk.

Any reproduction of information in datasheets of IMST GmbH is permissible only if reproduction is without alteration and is accompanied by all given associated warranties, conditions, limitations, and notices. Any resale of IMST GmbH products or services with statements different from or beyond the parameters stated by IMST GmbH for that product/solution or service is not allowed and voids all express and any implied warranties. The limitations on liability in favor of IMST GmbH shall also affect its employees, executive personnel and bodies in the same way. IMST GmbH is not responsible or liable for any such wrong statements.

Copyright © 2011, IMST GmbH

### 10.2 Contact Information

IMST GmbH

Carl-Friedrich-Gauss-Str. 2  
47475 Kamp-Lintfort  
Germany

T +49 2842 981 0            E [wimod@imst.de](mailto:wimod@imst.de)  
F +49 2842 981 299        I [www.wireless-solutions.de](http://www.wireless-solutions.de)